

## GR-65J075AM: DFN 8x8 Cascode GaN HEMT

### Description

GR-65J075AM is a normally-off GaN High electron mobility transistor (HEMT) device using the cascode configuration, which provides high breakdown voltage, high current and high operating speed which is suitable for high power applications.

### Key Specifications

Part Number	GR-65J075AM
V <sub>DSS</sub>	650V
V <sub>(TR)DSS</sub>	800V
R <sub>DS(ON)</sub> , typ.	75mΩ
Q <sub>G</sub> , typ.	12.5nC
Package	DFN 8 x 8 mm

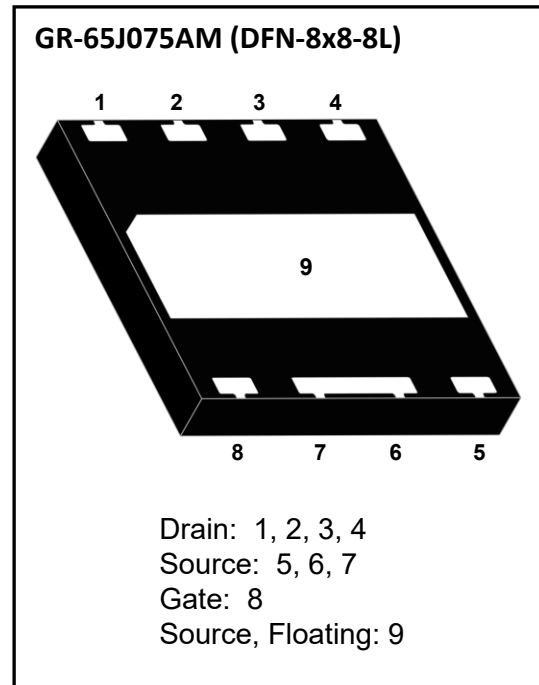

### Features

- Gate drive voltage compatibility (-20V to +20V)
- High operating frequency
- Low Q<sub>rr</sub>
- 1.5kV HBM ESD

### Applications

- Switch Mode Power Supplies (SMPS)
- AC-DC/DC-DC Converters: Boost, Buck, QR Flyback, ACF, AHB, LLC, Half/Full Bridge Application
- Motor Drives, Lighting, Server

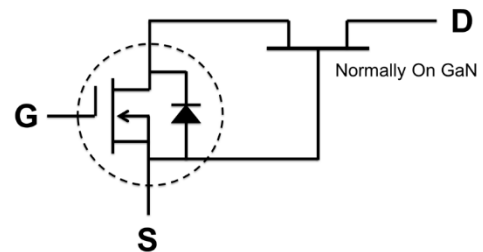

Cascode Device Structure

## 1- Electrical Characteristics

➤ **Table 1 Absolute maximum ratings**

Symbol	Parameter	Value	Unit
V <sub>DSS</sub>	Drain-source voltage	650	V
V <sub>(TR)DSS</sub>	Transient drain to source voltage <sup>a</sup>	800	V
V <sub>GSS</sub>	Gate- source voltage	-20 ~ +20	V
I <sub>D</sub>	Drain current (continuous) at T <sub>c</sub> = 25°C operation	21.4	A
	Drain current (continuous) at T <sub>c</sub> = 100°C operation	13.6	A
I <sub>D,Pulse</sub>	Pulsed drain current (pulse width: 10μs)	80.3	A
P <sub>D</sub>	Maximum power dissipation T <sub>c</sub> =25 °C	74	W
T <sub>c</sub>	Operating temperature	Case	-55 to +150 °C
T <sub>J</sub>		Junction	-55 to +150 °C
T <sub>S</sub>	Storage temperature	-55 to +150	°C
T <sub>SOLD</sub>	Soldering peak temperature <sup>b</sup>	260	°C
MSL	Moisture sensitivity level	MSL3	

a. In off-state, spike duty cycle D<0.01, spike duration <1μs

b. For 10 sec., 1.6mm from the case

➤ **Table 2 Thermal Characteristics**

Symbol	Parameter	Value	Unit
R <sub>θJA</sub>	Thermal resistance junction-ambient	65	°C/W
R <sub>θJC</sub>	Thermal resistance junction-case	1.7	°C/W

➤ **Table 3 Electrical Characteristics** ( $T_{CASE} = 25\text{ °C}$  unless otherwise stated)

Symbol	Parameter	Conditions	Values			Unit
			min.	typ.	max.	
$V_{(BL)DSS}$	Drain-source voltage	$V_{GS}=0V$	650	-	-	V
$V_{GS(th)}$	Gate threshold voltage	$V_{GS}=V_{DS}, I_D=1mA$	2.0	3.0	4.0	V
$R_{DS(on)}$	Static drain-source on-resistance	$V_{GS}=10V, I_D=5A, T_J=25\text{ °C}$	-	74	91	mΩ
		$V_{GS}=10V, I_D=5A, T_J=150\text{ °C}$	-	133	-	
$I_{DSS}$	Drain-source leakage current	$V_{GS}=0V, V_{DS}=650V, T_J=25\text{ °C}$	-	3.0	60	μA
		$V_{GS}=0V, V_{DS}=650V, T_J=150\text{ °C}$	-	15	-	
$I_{GSS}$	Gate-to-source forward leakage current	$V_{GS}=20V$	-	-	100	nA
	Gate-to-source reverse leakage current	$V_{GS}=-20V$	-	-	-100	
$C_{ISS}$	Input capacitance	$V_{GS}=0V, V_{DS}=400V, f=1MHz$	-	766	-	pF
$C_{OSS}$	Output capacitance		-	31.8	-	
$C_{RSS}$	Reverse transfer capacitance		-	2.42	-	
$Q_G$	Gate charge	$V_{GS}=0\sim 10V, V_{DS}=400V, I_{DS}=5A$	-	12.5	-	nC
$Q_{GS}$	Gate-source charge		-	3.20	-	
$Q_{GD}$	Gate-drain charge		-	2.40	-	
$Q_{OSS}$	Output charge	$V_{GS}=0V, V_{DS}=0\sim 400V$	-	52.6	-	nC
$t_{D(on)}$	Turn-on delay time	$V_{DS}=400V, V_{GS}=0\text{ to }10V, I_{DS}=2A, R_G=25\Omega$	-	10.5	-	ns
$t_{D(off)}$	Turn-off delay time		-	17.0	-	
$Q_{RR}$	Reverse recovery charge	$I_S=5A, V_{DS}=400V$	-	7.8	-	nC

## 2- Typical Characteristic Curves

Fig 1. On-Region Characteristics

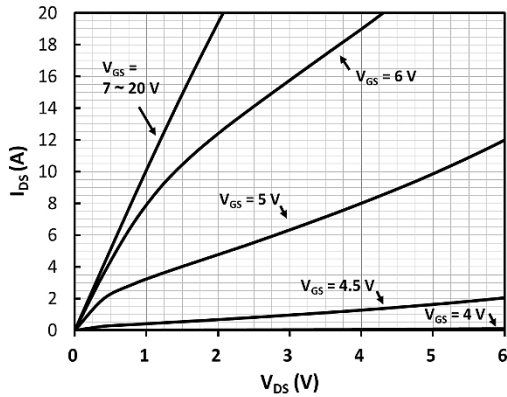

Fig 2. On-Resistance vs Drain Current and Temperature

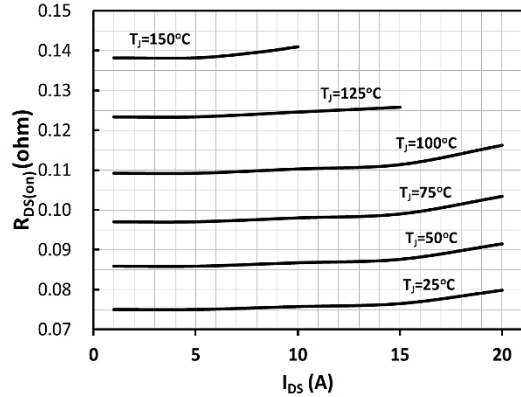

Fig 3. On-Resistance with Drain Current

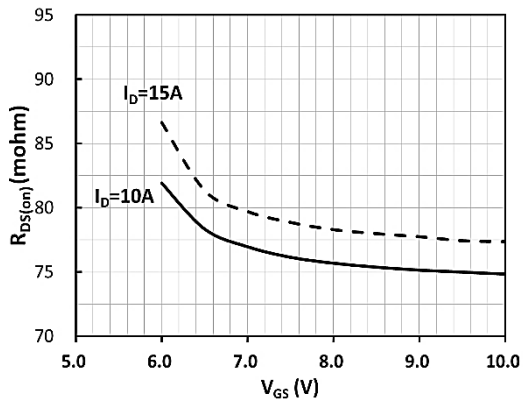

Fig 4. On-Resistance Variation with Temperature

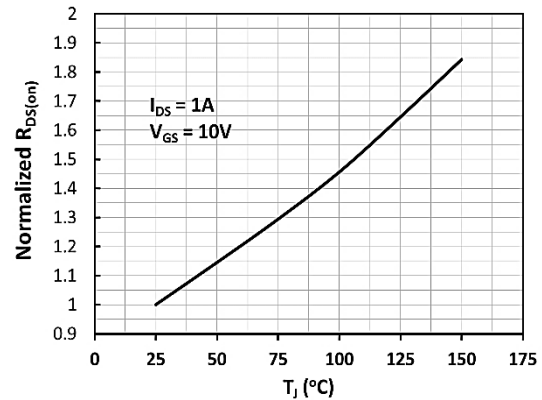

Fig 5. Threshold Voltage with Temperature

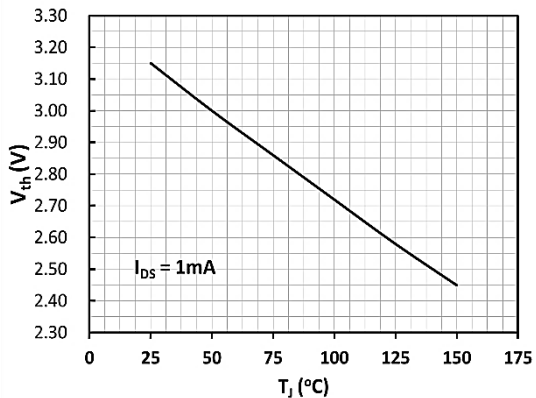

Fig 6. Capacitance Characteristics

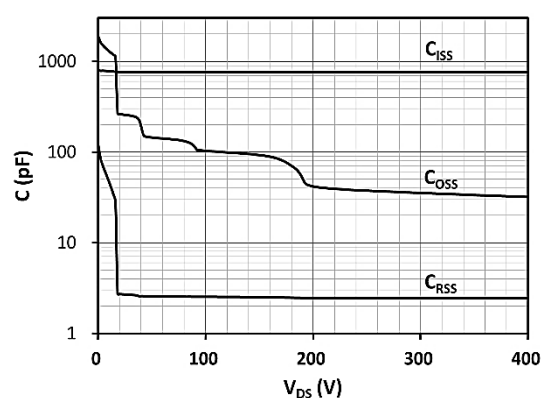

Fig 7. Gate Charge Characteristics, Qg

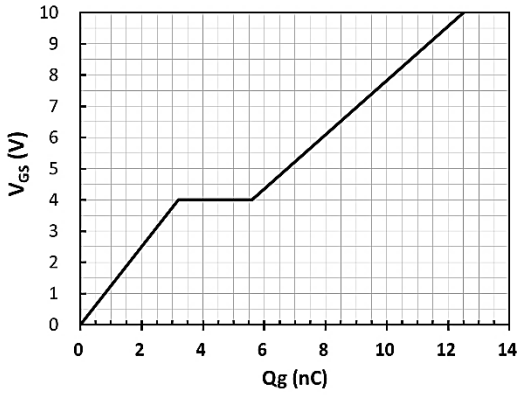

Fig 8. Capacitance Characteristics, Qoss

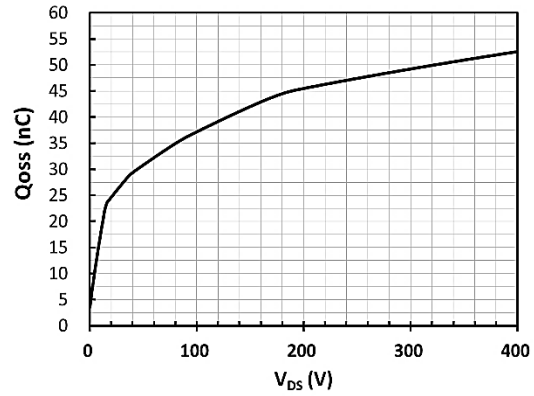
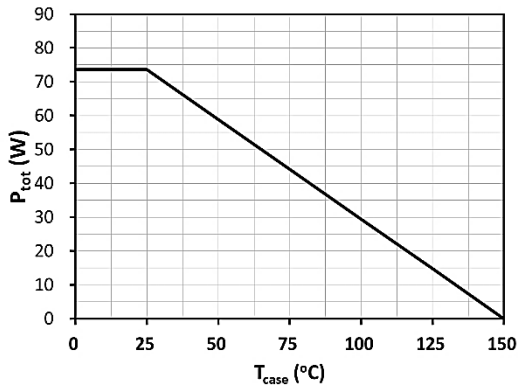
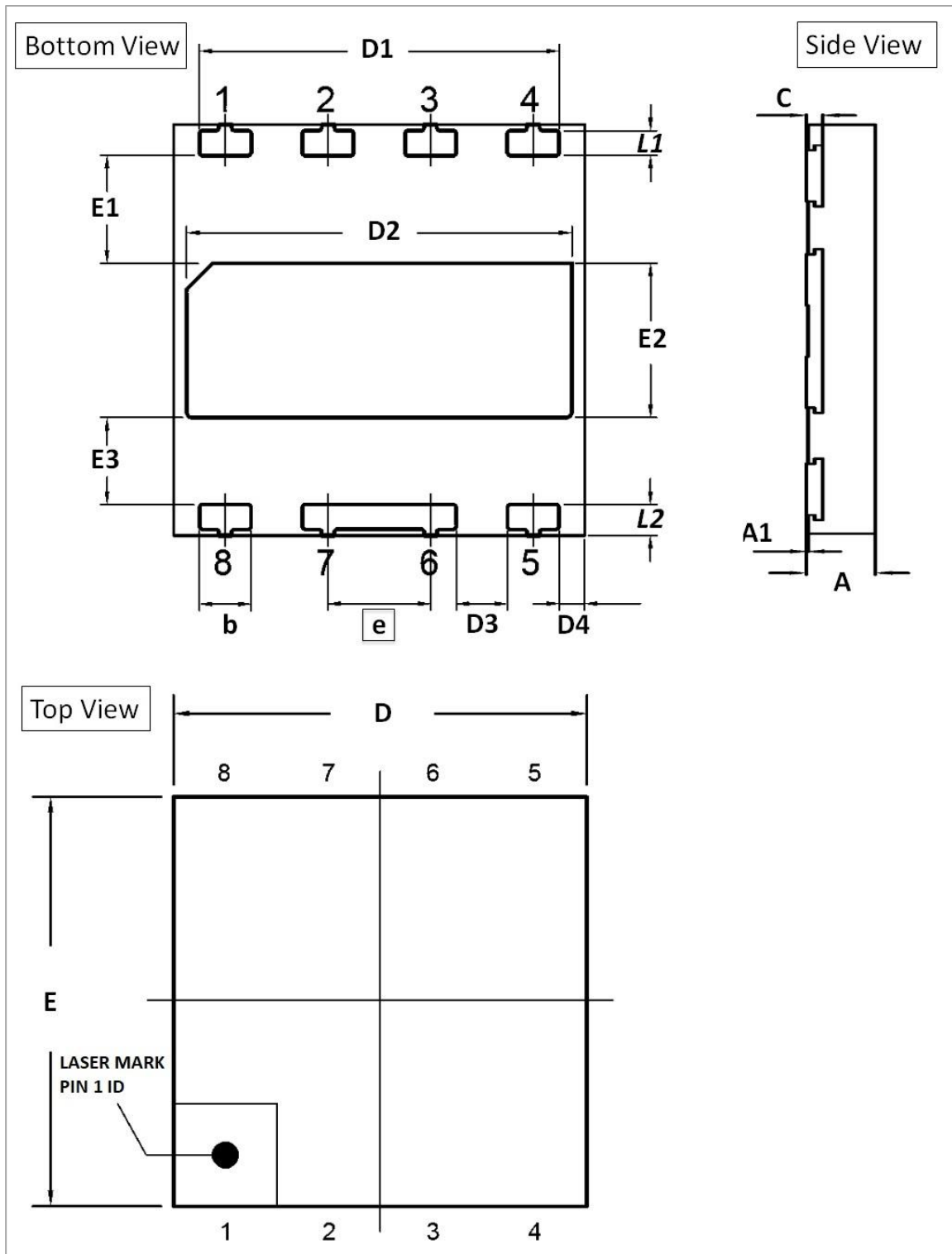

Fig 9. Power Dissipation Derating, Ptot



**3- Package Outline Dimensions, DFN-8X8-8L (GR-8080-M)**



➤ **Table 4 Dimension of DFN-8X8-8L (GR-8080-M)**

SYMBOL	DIMENSION (IN MM)			SYMBOL	DIMENSION (IN MM)		
	MINIMUM	NOMINAL	MAXIMUM		MINIMUM	NOMINAL	MAXIMUM
A	1.20	1.25	1.30	e	2.00 BSC		
A1	--	0.02	0.05	E	7.90	8.00	8.10
A2	0.203 REF			E1	2.00	2.10	2.20
b	0.95	1.00	1.05	E2	2.90	3.00	3.10
D	7.90	8.00	8.10	E3	1.60	1.70	1.80
D1	6.90	7.00	7.10	L1	0.38	0.48	0.58
D2	7.40	7.50	7.60	L2	0.50	0.60	0.70
D3	0.90	1.00	1.10				
D4	0.40	0.50	0.60				

**DFN-8X8-8L (GR-8080-M) Recommended PCB Soldering Footprint**

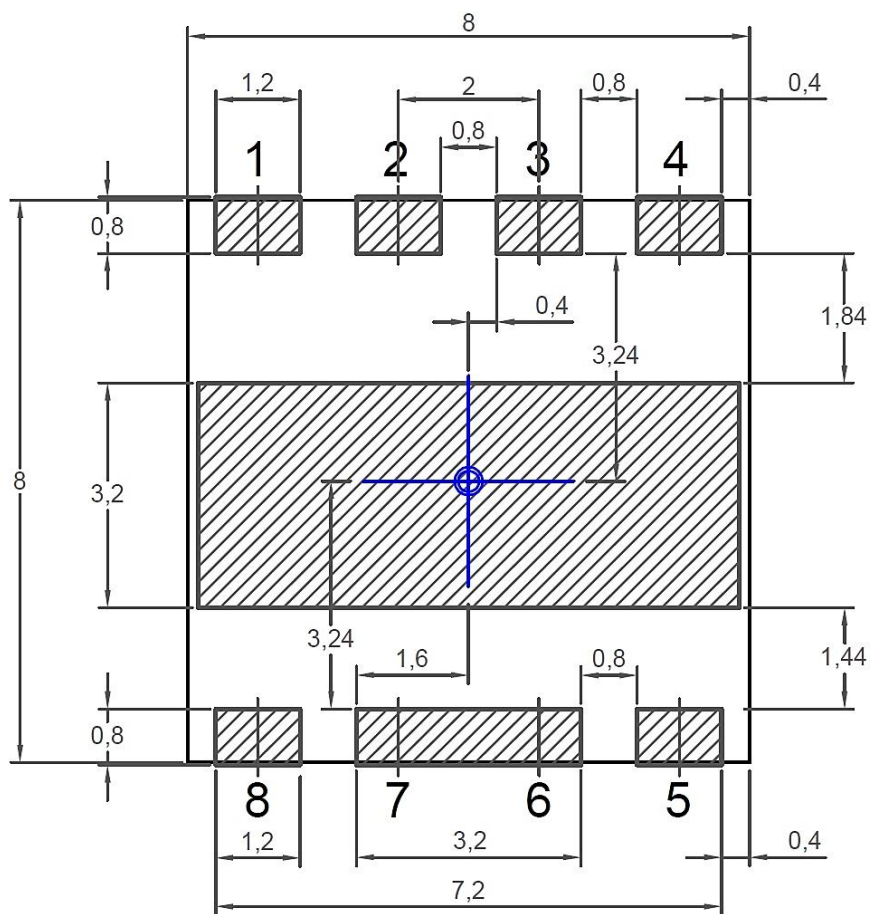

### 4- Tape and Reel Information

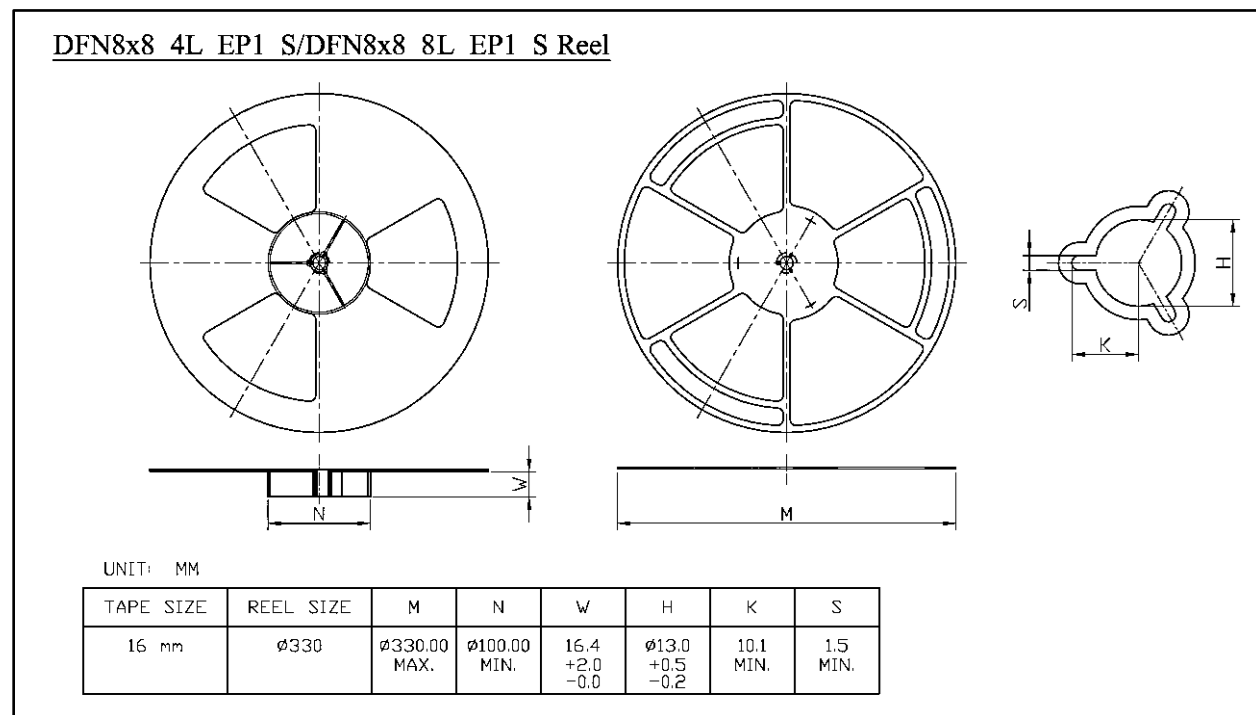
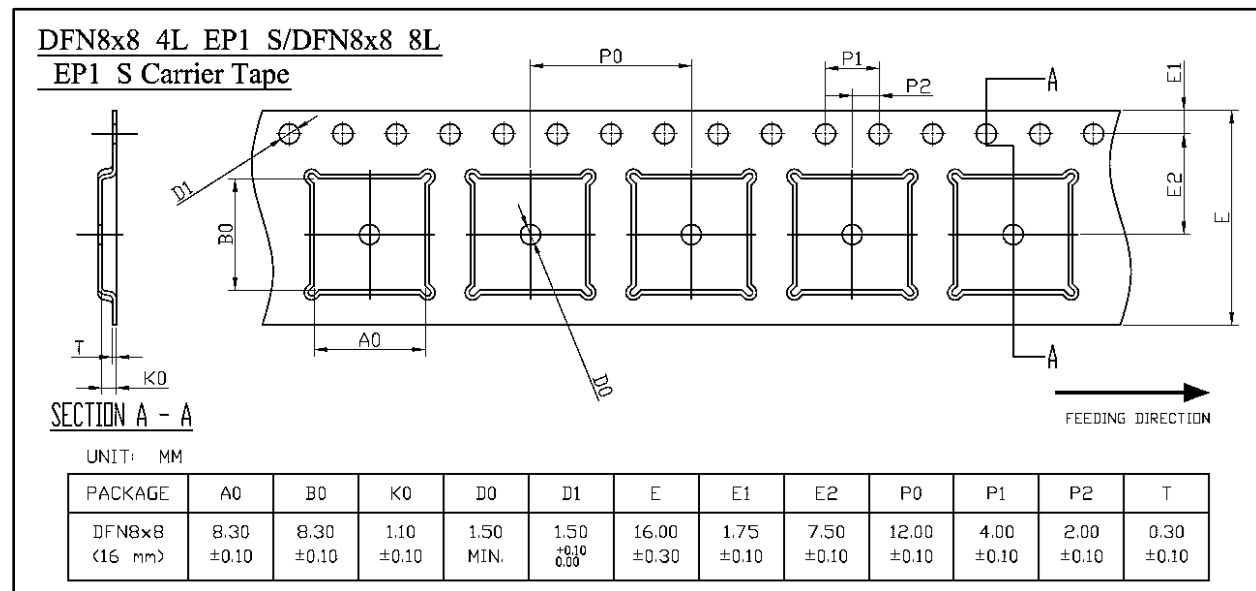

**5- Box Dimensions**

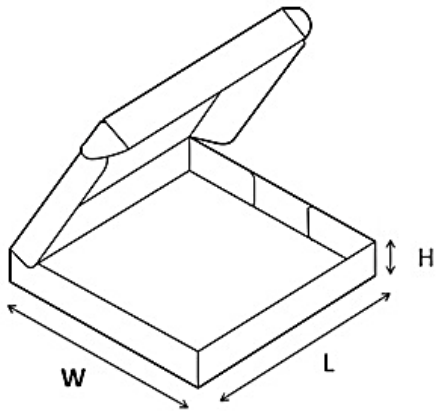

	Inner BOX, mm
W	340
L	360
H	50

1 Inner box contains 2500 components

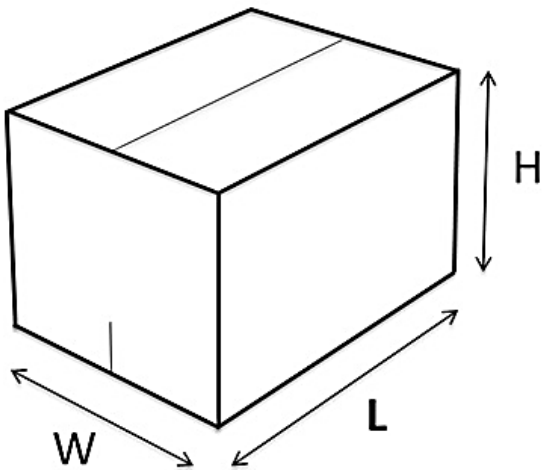

	Outer Carton, mm
W	360
L	380
H	290

Each Carton contains 5 boxes,  
 Total of 12500 components

## 6- Change Log

Version	Date	Description
01	Nov 28, 2023	Initial version
02	Jan 6, 2026	Electrical characteristics revised.
03	April 16, 2026	Electrical characteristics revised

### DISCLAIMER

Except for the written expressed warranties, MGT does not implicitly, by assumption or whatever else, warrant, undertake, promise any other warranty or guaranty for any MGT product. All information and technical specifications made available by MGT are for guidance only and we reserve the right to change or modify them without prior notice. Unless expressly stated in writing by MGT, we reject any guarantees, obligations, or warranties. All MGT products with the technical specifications described are suitable for use in certain applications. Operating, production, storage and environmental conditions can have a massive influence on the parameters mentioned in the data sheets, which cause the performance to vary over time. It is subject to the user's duty of care to design and validate his products in such a way that appropriate measures are taken, such as protective circuits or redundant systems to ensure the safety standards required in the application. MGT components are not designed or rated for *use in life support, rescue, safety critical, military, or aerospace applications where failure or malfunction could result in property or environmental damage, serious injury or death*. In the aforementioned cases, please contact us before using MGT products. In principle, we reserve all rights and MGT's general terms and conditions apply. You can find them on our website [www.mgt.co.com](http://www.mgt.co.com)